



EUROPA FACHBUCHREIHE
für Chemieberufe

Pipe System Technology

... an introduction

1st Edition

Authors:

Dr. Hans Jürgen Metternich

Antonius Kappe

Ralf Ißleib

Michael Dopheide

With the participation of Marc Babic, Karsten Fierke, Bernd Huesmann und Guido Scholz.

VERLAG EUROPA-LEHRMITTEL · Nourney, Vollmer GmbH & Co. KG

Düsseldorf Straße 23 · 42781 Haan-Gruiten

Europa-Nr.: 70773

Authors:

Dr. Hans Jürgen Metternich
Antonius Kappe
Ralf Ißleib
Michael Dopheide

With the participation of Marc Babic, Karsten Fierke, Bernd Huesmann und Guido Scholz.

Funded by:

Bundesministerium
für Bildung
und Forschung



Europäischer Sozialfonds
für Deutschland



Projekträger
im DLR

Project partners:**CREOS**

Lernideen und Beratung GmbH

EVONIK

Degussa GmbH

Infracor

GmbH

Provalidis

Partner für Bildung & Beratung

Chemie-Stiftung

Sozialpartner-Akademie

1st Edition 2019

Druck 5 4 3 2 1

All batches of this edition may be used concurrently in the classroom since they are unchanged, except for some corrections to typographical errors and slight changes in standards.

ISBN 978-3-7585-7077-3

All rights reserved. This publication is protected under copyright law. Any use other than those permitted by law must be approved in writing by the publisher.

Coverlayout by: CREOS Lernideen und Beratung GmbH, 33602 Bielefeld using technical drawings of the authors

© 2019 by Verlag Europa-Lehrmittel, Nourney, Vollmer GmbH & Co. KG, 42781 Haan-Gruiten
<http://www.europa-lehrmittel.de>

Typesetting: Typework Layoutsatz & Grafik GmbH, 86167 Augsburg
Printed by: M. P. Media-Print Informationstechnologie, 33100 Paderborn

Contents

INTRODUCTION	8
1 PIPES AND PIPE SYSTEMS	9
1.1 General information	9
1.1.1 Material	10
1.1.2 Nominal pressure	10
1.1.3 Nominal width	11
1.1.4 Temperature	12
1.1.5 Flow processes	12
1.1.6 Pipe characteristic curve	14
1.2 Pipe connections	15
1.2.1 General classification	15
1.2.2 Detachable connections	16
1.2.3 Non-detachable connections	18
1.3 Flange joint	19
1.3.1 Flange types	19
1.3.2 Screws	21
1.3.3 Installation	23
1.3.4 Tools	27
1.4 Connecting elements for pipes	28
1.4.1 Fittings	28
1.4.2 Screw pipes	29
1.5 Isometry of pipelines	30
1.5.1 Perspective and viewpoint	32
1.5.2 Isometric shading	34
1.5.3 Dimensions, line weights, and graphical symbols in isometric drawings	36
1.5.4 Troubleshooting in isometric drawings	38
1.6 Pipe systems	38
1.6.1 Linear expansion	38
1.6.2 Pipe supports	39
1.6.3 Graphical symbols	40
1.6.4 Labeling in accordance with flow medium	41
1.7 Questions on the chapter “Pipes and pipe systems”	43
2 FITTINGS	44
2.1 Introduction	44
2.2 Classification of fitting based on construction	44
2.2.1 Requirements of fittings	45
2.2.2 External impermeability	46
2.2.3 Internal impermeability	47
2.2.4 Pressure losses in fittings	47
2.2.5 Properties of fittings (basic structures)	48
2.3 Structures of fittings	48
2.3.1 General classification	48
2.3.2 Valves	49
2.3.3 Sliders	53
2.3.4 Cock	56
2.3.5 Flap	59
2.3.6 Diaphragm valve	62
2.4 Special fittings	64
2.4.1 Safety glass	64
2.4.2 Dirt trap	64
2.4.3 Sampling valve	65
2.5 Faults with fittings	65
2.5.1 Generic	65

2.5.2	Causes of damage to fittings	65
2.5.3	Measures to minimize/avoid damage.	66
2.6	Graphic symbols	67
2.6.1	Fittings	67
2.6.2	Actuators.	68
2.7	Questions on the chapter “Fittings”	69
3	SAFETY FITTINGS.	70
3.1	Introduction	70
3.2	Safety valve	70
3.2.1	Classification based on construction	70
3.2.2	Opening mechanism	71
3.2.3	Installation hints	72
3.3	Burst protection	73
3.3.1	Classification based on construction	73
3.3.2	Installation hints	74
3.4	Steam trap	74
3.4.1	Classification based on construction	75
3.4.2	Types of steam traps.	76
3.4.3	Installation hints	78
3.5	Return flow preventers.	78
3.5.1	Classification based on construction	78
3.5.2	Installation hints	79
3.6	Bleeding and venting valves	80
3.6.1	Bleeding valve.	80
3.6.2	Venting valve.	80
3.7	Anti-explosive devices	81
3.7.1	Flame arresters	82
3.7.2	Pressure release in a dust explosion	84
3.8	Questions on the chapter “Safety Fittings”	84
4	STATIC AND DYNAMIC SEALS	85
4.1	General information on seals.	85
4.1.1	Tasks of seals	85
4.1.2	Classification of seals	85
4.1.3	Waterproofing of static sealing surfaces.	85
4.1.4	Waterproofing of dynamic sealing surfaces	87
4.2	Static seals	88
4.2.1	Flat seals	89
4.2.2	Profile seals.	90
4.2.3	Welding ring seals.	91
4.2.4	Sealing compound	92
4.2.5	Membrane and bellows.	92
4.3	Seals in flange connections	92
4.3.1	Shapes of sealing surfaces	92
4.3.2	Types of flange seal installation	93
4.3.3	Sealing face pressure	94
4.3.4	Bolt force and torque	96
4.3.5	Leaking flange connections	99
4.4	Dynamic seals on pumps	100
4.4.1	Packing seal (packing gland)	100
4.4.2	Slide ring seals	102
4.4.3	Dynamic seals on piston pumps.	108
4.5	Questions on the chapter “Static and dynamic seals”	109
5	GENERAL PRINCIPLES OF CONVEYOR TECHNOLOGY	110
5.1	Definitions	110
5.1.1	Force.	110

5.1.2	Effort	110
5.1.3	Energy	110
5.2	Physical conveyance principles.	111
5.3	Basic Conveyance Principle (Working Approach)	112
5.3.1	Centrifugal force principle.	112
5.3.2	Displacement principle	112
5.3.3	Bernoulli principle	112
5.4	Conveyance of hard materials.	112
5.4.1	Discontinuous conveying	113
5.4.2	Continuous conveying	113
5.4.3	Conveying with machines.	113
5.5	Conveyance of liquids	117
5.5.1	Conveying via gradients	117
5.5.2	Conveying with a siphon.	117
5.5.3	Conveying with pressure.	118
5.5.4	Conveying with vacuum	118
5.5.5	Conveying by pumping.	119
5.6	Conveyance of gases	119
5.6.1	Classification of devices for conveyance of gas.	121
5.6.2	Compressors.	122
5.6.3	Blower.	124
5.6.4	Fans	124
5.6.5	Vacuum generator.	125
5.7	Questions on the chapter “Conveyor technology”	128
6	PUMP TECHNOLOGY	129
6.1	Principles of pump technology	129
6.2	Classification of pumps	129
6.2.1	Displacement machines	130
6.2.2	Continuous-flow machines	130
6.3	Classification of pumps based on working principle	131
6.3.1	Continuous-flow pumps (non self-priming).	131
6.3.2	Continuous-flow pumps (self-priming)	132
6.3.3	Displacement pumps (rocking or oscillating)	132
6.3.4	Displacement pumps (rotating).	132
6.4	Classification of pumps based on arrangement	134
6.4.1	Bed plate pumps.	134
6.4.2	Block pumps	134
6.4.3	Inline pumps	134
6.4.4	Vertical pumps	135
6.4.5	Submersible motor pumps	135
6.4.6	Submersible pumps	135
6.5	Classification of pumps based on seal type.	135
6.5.1	Pumps with shaft seal.	135
6.5.2	Pumps without shaft seal	135
6.5.3	Pumps with permanent magnetic coupling (magnetic pumps)	135
6.6	Important graphical symbols.	136
6.7	Hermetically sealed pumps	136
6.7.1	Construction of pumps with air gap	136
6.7.2	Construction of pumps with gap tube	137
6.8	Couplings.	137
6.8.1	Operation, disruptions and causes.	138
6.8.2	Operation after destruction of elastic packaging	139
6.8.3	Maintenance and repair of couplings	139
6.8.4	Protecting against accidental contact with a coupling.	140

6.9	Determining the discharge head of a pump	141
6.10	Questions on the chapter “Pump technology”	143
7	SPECIAL PUMP AND COMPRESSOR TECHNOLOGY	144
7.1	Centrifugal pumps	144
7.1.1	Function of a centrifugal pump	144
7.1.2	Construction of centrifugal pumps	144
7.1.3	Conveying principle of the centrifugal pump	145
7.1.4	Construction types	145
7.1.5	Characteristic curves	147
7.1.6	Use of energy for centrifugal pumps	150
7.1.7	Starting up procedure for centrifugal pumps (generic)	154
7.1.8	Errors and consequences when starting up centrifugal pumps	157
7.1.9	Malfunctions when operating centrifugal pumps	160
7.2	Side channel pumps	162
7.2.1	Construction of side channel pumps	162
7.2.2	Conveyance principle of a side channel pump	163
7.2.3	Gas conveyance in side channel pumps	165
7.2.4	Starting up procedure for side channel pumps (general)	166
7.2.5	Errors and consequences when starting up side channel pumps	167
7.2.6	Malfunctions when operating side channel pumps	167
7.2.7	Operational characteristics of side channel pumps	169
7.3	Piston pumps	169
7.3.1	Conveyance principle of a piston pump	170
7.3.2	Construction of a piston pump	171
7.3.3	Piston stroke and characteristics	173
7.3.4	Advantages and disadvantages of piston pumps	175
7.3.5	Starting up procedure for piston pumps (general)	175
7.3.6	Errors and consequences when starting up piston pumps	176
7.3.7	Malfunctions when operating piston pumps	177
7.4	Liquid ring compressors (Liquid ring pumps)	179
7.4.1	Functional principle of the liquid ring compressor (Liquid ring pump)	180
7.4.2	Working principle of liquid ring compressors (Liquid ring pumps)	180
7.4.3	Operational fluid	182
7.4.4	Liquid separator	182
7.4.5	Operating modes	182
7.4.6	Malfunctions when operating liquid ring compressors	183
7.5	Questions on the chapter “Special pumps and compressor technology”	184
8	MATERIALS AND MATERIAL DECOMPOSITION	185
8.1	Classification of materials	185
8.2	Properties of materials	185
8.2.1	Types of material stress	186
8.2.2	Plasticity and elasticity	186
8.2.3	Tensile stress	187
8.2.4	Hardness	188
8.3	Metals	188
8.3.1	Ferrous metals	188
8.3.2	Cast iron (> 1.7 % C)	189
8.3.3	Steel materials (< 1.7 % C)	190
8.3.4	Non-ferrous metals	195
8.3.5	Heavy metals	196
8.3.6	Light metals	200
8.4	Non-metals	202
8.4.1	Organic materials	202
8.4.2	Inorganic materials	207
8.5	Composites	208
8.5.1	Effect of materials contained within composite	208
8.5.2	Structure of composites	209

8.6	Material decomposition	209
8.6.1	Physical material deterioration	209
8.6.2	Chemical material deterioration through corrosion.	210
8.7	Questions on the chapter “Materials and material deterioration”	212
9	CORROSION PROTECTION	214
9.1	Non-metallic coatings	214
9.1.1	Organic coatings.	214
9.1.2	Inorganic coatings.	214
9.2	Metallic coatings	215
9.3	Constructive and cathodic corrosion protection	216
9.4	Questions on the chapter “Corrosion protection”	217
LIST OF FIGURES		218
KEYWORD INDEX		219

Introduction

E-Learning for the chemical profession

Many topical areas in the field of pipe system technology can only partially be described in a way that stands out through conventional media elements such as photos, graphics and texts. Understanding the interaction of functional links or processes, amid the increasing complexity of the subject matter to be conveyed, requires considerable abstractive ability, and is thus ultimately a question of the imagination of the learner. However, since it is unrealistic to presume the latter ability in all cases, there is a demand for new concepts and didactic approaches, which expand the potential for knowledge transfer of a book via modern media and in so doing, can both create a deeper understanding and improve the sustainability of the learning process.

The current textbook—**pipe system technology**—is a component of such cross-media knowledge transfer. The subject matter is closely oriented to the vocational training regulations of typical professions in industry, such as chemical technician, pharmaceutical technician or production specialist, but also to the maintenance vocations in the chemical industry (industrial mechanic and plant mechanic) as well as certain laboratory professions. The concept impresses as a meaningful supplement to the subject matter with interactive learning media. These optional, interactive software modules support the learning process by overcoming the very “limit of comprehension”, which presupposes a far-reaching abstractive ability. Processes and devices used in everyday chemical operations and laboratory work are attractively set using animations or visualized in a manner to boost understanding.

The existing highly practical draft is part of the multimedia collection of learning content, which have been compiled as part of the project **E-Learning for the chemical profession** (ELCH). The scientific monitoring, which supported the project progression and the content creation, was used to ensure the quality of solutions with regard to media studies and ergonomics.

The ELCH project, financed with the support of the German Ministry of Education and Research and funds from the European Social Fund, represents a successful attempt to create a comprehensive learning scenario, which combines established means with appealing, digital learning media.

The authors of the ELCH consortium

Please find **additional digital learning material** following: <https://vel.plus/70773-WBT>

1 Pipes and Pipe Systems

1.1 General information

Pipes are tubular components, which connect individual system components with each other. Their function consists of conveying and transferring away media. Pipes are divided into two main groups: production pipes and transport pipes. Production pipes are pipes, which are required within production facilities. The term transport pipe, meanwhile, refers to pipes which are deployed for the conveyance of media over long distance (pipelines).

Since the pipes within chemical plants tend to be sealed systems, these pipes are also known as pipe systems or pipe networks.

In the chemical production plant, pipes are subject to certain operational requirements, such as:

- the chemical influences of the conveyed medium
- the temperature of the conveyed medium
- the pressure of the conveyed medium
- the flow speed of the conveyed medium



Figure 1-1 Pipes at Marl Chemical Park

The operational requirements influence the choice of:

- material
- wall thickness
- pressure class (PN)
- nominal diameter (DN) of the required pipe

The design of a pipe, such as the wall thickness and material used, may be defined in a selection of pipe classes that is specific to the particular company. The EU pipe classes form the basis for this selection.

1.1.1 Material

The selection of the material (e. g. steel, stainless steel, copper, PVC, glass) for a pipe is in line with the following requirements:

- Static and dynamic stresses

e. g. maximum operating pressure, alternating pressure load

for example the following are suited:

Material	Property	Application
Stainless steel	High tensile strength	Product-conveying pipes in operation

- Mechanical stresses

e. g. flow velocity, abrasion resistance

for example the following are suited:

Material	Property	Application
Steel	Abrasion-proof surface	Pipe for liquids, which contain solid particles

- Corrosion resistance

for example the following are suited:

Material	Property	Application
Glass	Resistant against concentrated acids	Reactor vessel

- Thermal conductivity

for example the following are suited:

Material	Property	Application
Aluminum	Good thermal conductivity	Heat exchanger

- Electrical conductivity

for example the following is **not** suitable:

Material	Property	Application
PVC	Static charge	No applications in areas at risk of explosion

1.1.2 Nominal pressure

The nominal pressure PN (Pressure Nominal) is the benchmark for a nominal pressure stage and indicates the maximum tolerable limit for the internal overpressure of the pipe system. The nominal pressure is specified without units, but the number in context refers to the unit of bar. The nominal pressure reading always assumes an operating temperature of 20 °C.

The nominal pressure stages have been determined with numbers that are vital for everyday operational duties. In accordance with DIN EN 1333, the definition and selection of the nominal pressure (PN) is described. The following nominal pressure stages can be selected:

PN 2,5	PN 25	PN 160
PN 6	PN 40	PN 250
PN 10	PN 63	PN 320
PN 16	PN 100	PN 400

1.1.3 Nominal width

Pipes have diameters ranging from a few millimeters up to several meters. Pipes made of steel can be divided into a further two groups:

- Pipes for general use and
- Precision pipes.

The **pipes for general use** are characterized by the nominal width (DN, Diameter Nominal). This is a variable and without unit. In pipe terminology, the variable is defined as a dimensionless whole number with the DN abbreviation. Each nominal width is assigned to a defined connection size. The nominal widths are graduated such that the conveying capacity of a pipe from one nominal width to the next increases by around 60–100%.

Table 1-1 Nominal widths and diameter

Nominal width DN	Ø external	Nominal width DN	Ø external
10	17.2	150	168.3
15	21.3	200	219.1
20	26.9	250	273
25	33.7	300	323.9
32	42.4	350	355.6
40	48.3	400	406.4
50	60.3	450	457
65	76.1	500	508
80	88.9	600	610
100	114.3	700	711
125	139.7	800	813

Based on the wall thickness of the pipe, there is a corresponding reduction, starting from the external diameter of the specific nominal width of the pipe cross-section. For pipes in general use, there are various pipe fittings. For drinking water pipes, galvanized steel pipes with threaded connections are also used.

For **precision pipes**, the external pipe diameter is specified to the nearest millimeter, e.g. Ø6, Ø8, Ø10, Ø12, Ø14, Ø16 etc.. These pipes are also produced with varying wall thicknesses.

1.1.4 Temperature

The Temperature, at which the fluid flows through the pipe system, influences the strength of the material. This ultimately also affects the permissible operating overpressure, with which the system can be operated.

The operating temperature, for which the nominal pressure (PN) applies, is determined at 20 °C. If the temperature increases, the strength of the material is reduced and hence also the maximum permissible pressure load of the pipe. This link must be taken into account by the constructor of a pipe system.

In Figure 1-2, the dependence of the permissible operating overpressure on temperature is shown. Here, two materials are compared, which are often used for pipes. Material S235JR is a structural steel, and material number 1.4571 stands for a non-rusting chrome-nickel steel (X6CrNiMoTi17-12-Z).

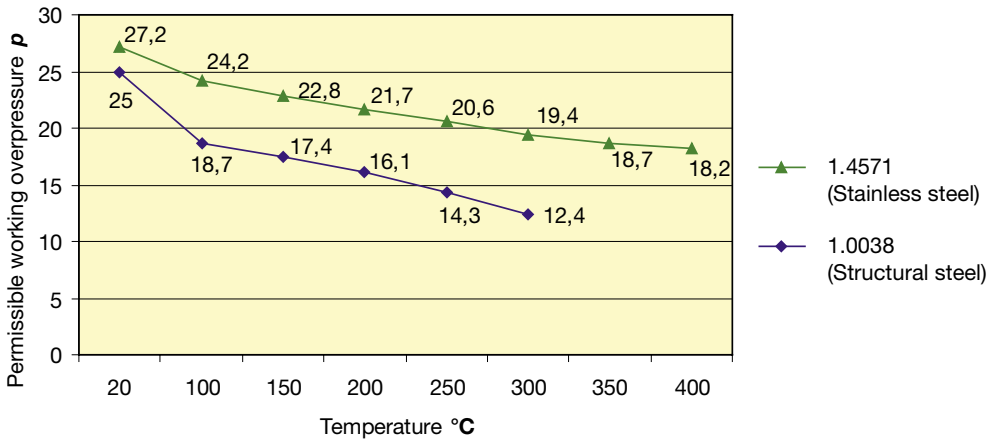

Figure 1-2 Dependence of the permissible operating overpressures on temperature

1.1.5 Flow processes

As regards flow processes in pipes, a distinction is made between two forms of flow:

- laminar flows and
- turbulent flows.

For **laminar flows**, the liquid particles move while equidistant from the pipe walls in an axial direction. Laminar flows ensue when both the resistances as well as the flow velocities along the pipe are small.

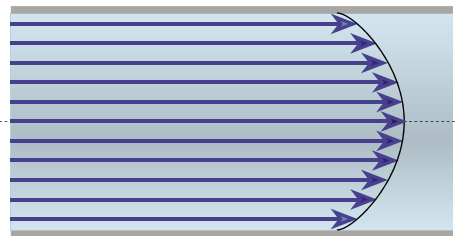
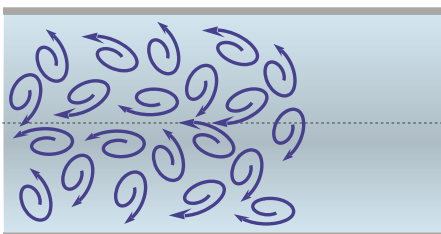

Figure 1-3 Laminar flow



For **turbulent flows**, the liquid particles move at continually varying distances from the pipe walls in an axial direction. Such turbulent flow occurs with a greater flow velocity and is aided by any resistances in the pipe (rough wall, fittings such as shut-off devices, measurement devices etc.).

Figure 1-4 Turbulent flow

Speed

The speed at which a liquid or gas moves through a pipe is described as the flow velocity. It is low within a pipe system with large cross-sections and vice versa. The flow velocity is measured in m/s and is represented by v .

$$\text{Velocity, } v = \frac{s}{t}$$

where $s = \text{Distance (distance covered)}$

$t = \text{Time}$

Volume flow

Volume flow describes the volume, which flows through a pipe within a specific time period. The volume flow remains the same at any point within a pipe system. It is measured in unit volume per time period (L/s or m³/h) and represented by the symbol \dot{V} .

$$\text{Volume flow, } \dot{V} = A \cdot v$$

where $A = \text{Area of the pipe cross-section at the point in question}$

$v = \text{Flow velocity}$

Mass flow

The mass, which flows through a pipe within a specific time period, is described as mass flow. The mass flow remains the same at any point within a pipe system. It is measured in kg/s or t/h and is represented by the symbol \dot{m} .

$$\text{Mass flow, } \dot{m} = \dot{V} \cdot \rho$$

where $\rho = \text{density of liquid}$

Continuity equation

Within the body sections of a pipe, the volume flow $\dot{V} = A \cdot v$ remains constant. If the cross-section of a pipe changes, likewise the flow velocity v will vary.

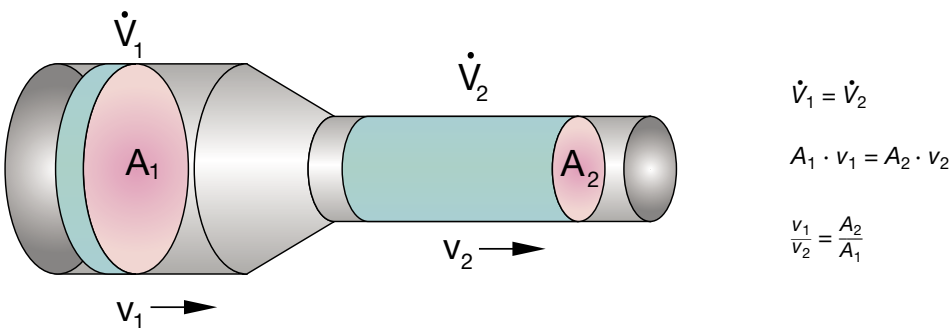

Figure 1-5 Continuity equation

The flow velocities therefore vary in inverse proportion to the corresponding cross-sectional pipe area (A).

Example Calculation of the flow velocity

In a pipe of nominal width DN 50, a medium flows with a speed of $v_1 = 1.56$ [m/s]. What does the flow velocity of the material become if the pipe narrows to DN 25?

$$\begin{array}{ll} v_1 = 1.56 \text{ [m/s]} & d_1 = 54.5 \text{ [mm]} \\ & \text{(DN 50: } d = 60.3 \text{ [mm]} - 2 \cdot 2.9 \text{ [mm] wall thickness)} \\ v_2 = ? \text{ [m/s]} & d_2 = 27.9 \text{ [mm]} \\ & \text{(DN 25: } d = 33.7 \text{ [mm]} - 2 \cdot 2.9 \text{ [mm] wall thickness)} \end{array}$$

The following applies:

$$\dot{V}_1 = \dot{V}_2 \quad \text{and} \quad A_1 \cdot v_1 = A_2 \cdot v_2$$

Which means:

$$A_1 \cdot v_1 = A_2 \cdot v_2 \quad \left| A = \frac{d^2 \cdot \pi}{4} \text{ insert in formula} \right.$$

$$\frac{d_1^2 \cdot \pi}{4} \cdot v_1 = \frac{d_2^2 \cdot \pi}{4} \cdot v_2 \quad \text{rearranging the equation (} v_2 \text{)}$$

$$v_2 = \frac{d_1^2 \cdot v_1}{d_2^2}$$

After inserting the numerical values $v_1 = 1.56$ [m/s]; $d_1 = 54.5$ [mm] and $d_2 = 27.9$ [mm] it follows

$$v_2 = \frac{(54.5 \text{ [mm]})^2 \cdot 1.56 \text{ [m} \cdot \text{s}^{-1}\text{]}}{(27.9 \text{ [mm]})^2}$$

$$v_2 = \frac{2,970 \text{ [mm}^2\text{]} \cdot 1.56 \text{ [m} \cdot \text{s}^{-1}\text{]}}{778 \text{ [mm}^2\text{]}}$$

The result is $v_2 = 6.0 \left[\frac{\text{m}}{\text{s}} \right]$.

The DN 25 pipe has a diameter only around half the size (around twice as small) as the DN 50 pipe. The flow velocity, however, increases around fourfold, because the cross-sectional area of the pipe has been reduced to approximately one quarter.

1.1.6 Pipe characteristic curve

The material flow in a pipe network is hampered by frictional processes. This can be seen in the form of pressure loss along a pipe. The degree of the pressure loss depends among other things on:

- the roughness of the pipe wall,
- the fittings, e. g. shut-off devices, safety devices, thermowell pipes,
- the viscosity and density of the pumped medium and
- the flow velocity or volume flow.

These “hindrances” to the material flow are expressed in the pipe characteristic curve (or system characteristic curve, Figure 1-6).

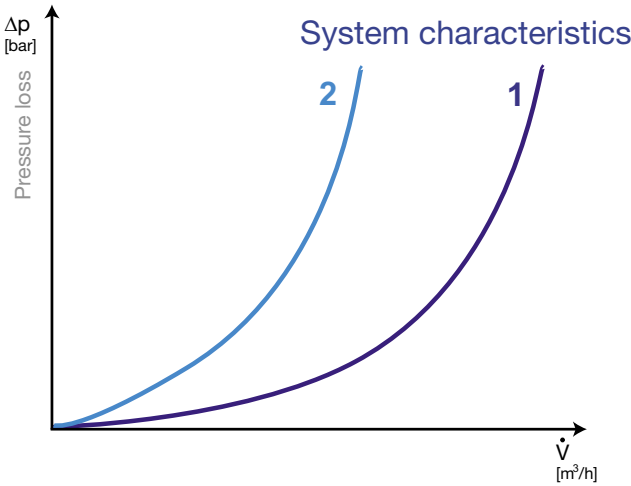

Figure 1-6 System characteristic curves

The pipes characteristic curve represents the link between pressure loss in the pipe and the volume flow.

Figure 1-6 allows the following conclusions:

- Pipe network 2 has a higher pressure loss than pipe network 1
- Pipe network 2 has a higher resistance than pipe network 1 (e.g. more valves, smaller diameter)

1.2 Pipe connections

To connect individual pipes to each other, various different types of connection are in use, in each case striving to ensure the maximum possible sealing performance.



However, not only are pipes connected to each other, but in the same way, the equipment used within pipe systems (e.g. fittings).

1.2.1 General classification

Pipe connections are divided into two different main groups: detachable and non-detachable connections.

Table 1-2 Pipe joints

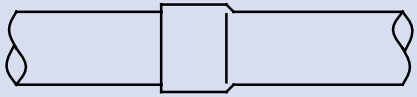
Pipe joint	Diagram	Detachable/ non-detachable
Weld joint		Non-detachable
Flange joint		Detachable

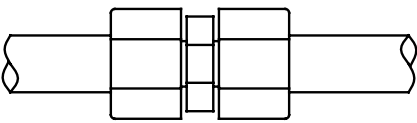
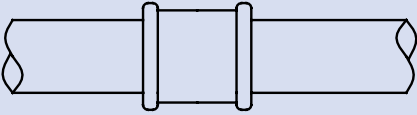
Pipe joint	Diagram	Detachable/ non-detachable
Sleeve joint		Detachable
Bonded joint		Non-detachable
Bolted joint with seal in thread		Detachable
Screwed pipe joint		Detachable
Press-fitted joint		Non-detachable

1.2.2 Detachable connections

The sleeve connection is hardly ever used within chemical plants. It is predominantly used within sewer networks, e.g. made of plastic or concrete. Sleeve connections may only be exposed to low pressure (a few mbar overpressure).

Flange connections, as an additional form of detachable connections, are separately described in Chapter 1.3.

Screw pipe

The screw pipe consists of a union nut, a cutting ring or clamping rings and the connecting members. Watertightness is achieved by tightening of the union nut on the members, whereby the sealing element is the cutting ring or the clamping rings. These pipe connections are characterized by the fact that they can often be reused multiple times.

Example Cutting ring connection

When tightening the screw connection, the cutting ring penetrates the pipe to a small extent and de-forms it to a minor extent. The seal of the screw pipe is ensured by the necking and by the conical areas between the screw joint and cutting ring.

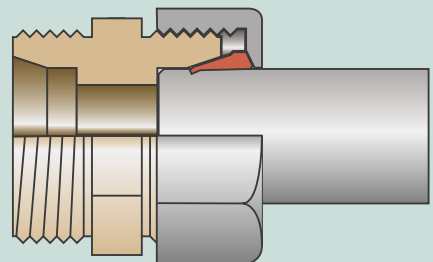

Figure 1-7 Diagram of a cutting ring connection

Example Clamping ring connection

When tightening the screw connection, the front clamping ring is elastically deformed, since when sealing, it is in contact with the surfaces of the pipe. The rear ring clamps the pipe in an area in the vicinity of the point at which the nib of the clamping ring is holding the pipe. The use of the rear ring increases the resistance of the connection to vibrations.

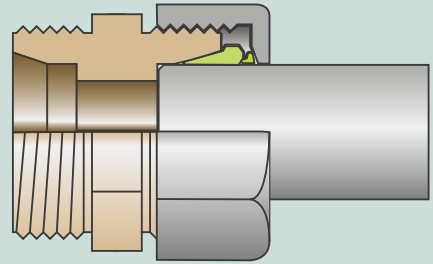

Figure 1-8 Diagram of a clamping ring connection

During the initial assembly, the pipe end is shifted up until the stop in the screw pipe and the union nut is tightened finger tight. Subsequently, an open end wrench is used to further tighten the union nut. During the assembly of the screw pipe or the re-assembly thereof, the manufacturer's details concerning the speed during tightening of the union nut must be complied with. In addition, the pipe must not be subject to any damage in the area of the screw joint, since this could otherwise cause leakage.

Table 1-3 Cutting ring and clamping ring compared

Connection	Advantages	Disadvantages
Cutting ring	<ul style="list-style-type: none"> • Low acquisition costs for unalloyed steel design • No cross-sectional change in the internal diameter • Designed for high pressures 	<ul style="list-style-type: none"> • Non self-locking • Only applicable for up to medium pipe diameters
Clamping ring	<ul style="list-style-type: none"> • Self-locking • No "eating away" of the thread, since surface silver-plated • Designed for high pressures 	<ul style="list-style-type: none"> • Higher acquisition costs compared to the cutting ring connection • Slight curvature in the internal diameter • Only applicable for up to medium pipe diameters

The pipe diameters (external— \varnothing in mm) for all screw joints are regulated in accordance with DIN 3851, in which the preferred pipe diameter is specified with $\varnothing 3$, $\varnothing 4$, $\varnothing 5$, $\varnothing 6$, $\varnothing 8$, $\varnothing 10$, $\varnothing 12$, $\varnothing 14$, $\varnothing 16$, $\varnothing 20$, $\varnothing 25$, $\varnothing 30$ and $\varnothing 38$.

Screw connection with seal in thread

Pipes, which carry drinking water, service water or heating gas, often have so-called thread fittings connected. The thread at the end of the pipe and the thread fitting is a Whitworth pipe thread. The internal thread is cylindrical and depending on the design, the external thread may be cylindrical or conical. The dimensions of the Whitworth pipe thread are specified in inches.

Example Screw connection with seal in thread

When assembling pipe sections, a sealant consisting of hemp or PTFE tape is used. The external thread is wrapped before insertion into the internal thread with the sealant. The sealant should not be applied too thickly, since this may cause the fitting to break otherwise.

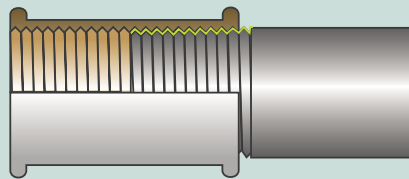

Figure 1-9 Diagram of a seal

Discourse Characteristics when sealing

- If necessary, the smooth thread should be slightly scraped with a metallic saw blade, while ensuring that this does not adversely affect the threading function. For brass, this is always necessary.
- When sealing with hemp, several fibers are taken from the plait and not wound with each other but left broad and thin.
- The hemp or PTFE tape is wound from the pipe end or the start of the thread in the direction of rotation of the thread around the pipe. Prior to this, the hemp is laid over the thread once in a longitudinal direction.

Caution: If the hemp or PTFE tape is wound around the thread other than as specified, it may become dislodged from the thread during the process of screwing together! To improve the watertightness, for hemp (but not PTFE tape), a fatty paste may be applied.

- The depth of the thread must never be excessive, since the external part may become damaged otherwise. After the process of screwing together, the end of the thread not completely cut out should remain visible.
- When the thread is sealed using PTFE tape there must be no, and with hemp-sealed thread a maximum of a quarter turn in the reverse direction, since otherwise the leakproof quality of the connection is not guaranteed.

1.2.3 Non-detachable connections**Welded connection**

In the field of pipe connection technology, the use of welded connections is preferred since they are the most cost-effective option. These involve material-integrated bonds and guarantee absolutely no leakage. The thermal and mechanical stress of welded connections depends on the welding material, the welding method and the degree to which the preparations for the welding work proceed smoothly.

In industry, welded seams on pipes, which are used for the transport of hazardous materials, are subject to multiple tests (e. g. pressure tests, X-ray, leakage tests).

Adhesive joint (sleeve)

Adhesive joints in pipe systems are manufactured using PVC cement sockets or PVC pipe fittings and a suitable adhesive. Not all plastics can be bonded to the same extent and hence uniformly. The cause is the wide-ranging chemical composition of plastics and the resulting differences in deformation when exposed to mechanical strains.

If work is carried out with PVC pipes, it is advantageous to use an adhesive with a solvent. The solvent diffuses into the surface of the sealing point and thus facilitates the interaction between the adhesive and the parts to be connected together. This type of adhesive joint is comparable to the welding of plastics, but since it is carried out under cold conditions, it is referred to in terms of adhesives.

Press connection (sleeve)

The connection of pipes with the use of press connections is increasingly popular in areas of drinking water, rainwater, heating technology, compressed air and gas pipes. With the pressing tool (hydraulic pliers), the installation of the pipes can be performed swiftly and cleanly. The pipe connection is made without exposing the pipe material to any thermal stress. The key when using press connections, is to ensure that with consideration of the material to be conveyed, the correct choice of fitting and O ring seal is ensured. The pipe is inserted up to the stop point into the fitting (e.g. sleeve) and then pressed with the pressing tool. The pipe should not be exposed to any sharp outside burrs, since otherwise the O ring will be damaged.

Solder connection (sleeve)

When connecting pipes via soldering, this involves identical or differing metallic materials being bonded to each other. This method is mainly used for copper pipes and the scope of application is comparable to that of press connections. For the soldering process, a heat source is always required, to ensure the solder can be melted.

1.3 Flange joint



Flanges are governed by dimensional standards that are independent of the flange type. As a result, each standard applies to any flange with a particular nominal diameter and nominal pressure. All flanges have a bolt holes distributed evenly around the flange. The number of these holes is always a multiple of four.

1.3.1 Flange types

Different types of flange are used depending on the particular application, as listed in table 1-4.

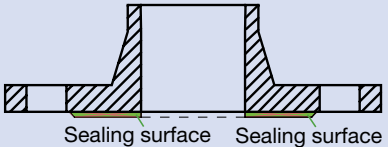
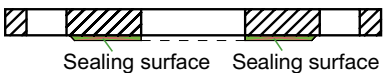
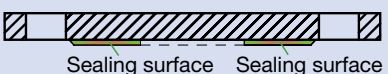
Table 1-4 Flange joints

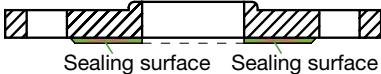
Type	Diagram	Description
Welding neck flange		Has a neck that can be welded to—is applied to end of pipe
Flat flange		Has no welding neck—is slipped onto the pipe for welding
Blank flange		A flange with no through-holes that closes up the pipe end

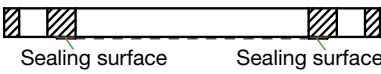
Type	Diagram	Description
Screwed flange		Generally has an inner thread (Whitworth) that allows it to be screwed onto the end of the pipe
Lapped flange (collared flange)		Is slipped loosely over the pipe and requires a welding collar for it to be attached onto the end of the pipe—remains mobile (rotatable)
Process-vessel flange		Primarily used for boilers, vessels, and similar components—has different dimensions

Flanges are also classified by the shape of their sealing faces. The different sealing face shapes are referred to by different code letters. The dimensions for the sealing faces are always based on the thickness of the flange face. The protrusions and recesses for tongue and groove sealing faces and the like are then designed accordingly.

Table 1-5 Areas of application for various flanges (pressure)

Shape	Code letter		Applicable for nominal pressure											
	Old	New	1	6	10	16	25	40	64	100	160	250	320	400
Flat raised face	C	B1	■	■	■	■	■	■						
	D	B1					■	■						
	E	B2							■	■	■	■	■	■
Tongue and groove	F	C			■	■	■	■	■	■				
	N	D			■	■	■	■	■	■				
Lens gasket	L								■	■	■	■	■	■

The number of threaded bolts required for a flange joint with a particular pressure und nominal diameter is given in table 1-6.